

## Features

- Push switch option
- Compact, rugged design
- High reliability
- Metal bushing/shaft

## Applications

Level control, tuning and timer settings in:

- Audio-visual equipment
- Consumer electric appliances
- Radios
- Musical instrumentation
- Communications equipment

# PEC11 Series - 12 mm Incremental Encoder

## Electrical Characteristics

Output .....	2-bit gray code
Closed Circuit Resistance .....	3 ohms maximum
Contact Rating .....	1 mA @ 5 VDC
Insulation Resistance .....	100 megohms @ 250 VDC
Dielectric Withstanding Voltage	
Sea Level .....	300 VAC minimum
Electrical Travel.....	Continuous
Contact Bounce (15 RPM).....	5.0 ms maximum**
RPM (Operating).....	60 maximum**

## Environmental Characteristics

Operating Temperature Range .....	-30 °C to +70 °C (-22 °F to +158 °F)
Storage Temperature Range .....	-40 °C to +85 °C (-40 °F to +185 °F)
Humidity .....	MIL-STD-202, Method 103B, Condition B
Vibration .....	30 G
Contact Bounce.....	10~55~10 Hz / 1 min. / Amplitude 1.5 mm
Shock .....	100 G
Rotational Life .....	30,000 cycles minimum
Switch Life.....	20,000 cycles minimum
IP Rating.....	IP 40

## Mechanical Characteristics

Mechanical Angle.....	360 ° continuous
Torque	
Running .....	50 to 200 gf.cm (0.68 to 2.7 oz.-in.)
Mounting.....	10.2 kgf.cm (8.83 lb.-in.) maximum
Shaft Side Load (Static).....	2.04 kgf (4.5 lbs.) minimum
Weight .....	5 gm (0.17 oz.) maximum
Terminals .....	Printed circuit board terminals
Soldering Condition	
Wave Soldering.....	Sn95.5/Ag2.8/Cu0.7 solder with no-clean flux: 260 °C max. for 3-5 seconds
Hand Soldering.....	Not recommended
Hardware .....	One flat washer and one mounting nut supplied with each encoder.

## Switch Characteristics

Switch Type .....	Contact Push ON Momentary SPST
Power Rating (Resistive Load) .....	10 mA at 5 V DC
Switch Travel .....	0.5 ± 0.2 mm
Switch Actuation Force .....	610 ± 306 gf (8.47 ± 4.24 oz.-in.)

## How To Order

	<b>PEC11 - 4 0 20 F - S 0012</b>
Model .....	PEC11
Terminal Configuration .....	4 = PC Pin Horizontal/Rear Facing
Detent Option .....	0 = No Detents (12, 18, 24 pulses) 1 = 18 Detents (18 pulses) 2 = 24 Detents (12, 24 pulses)
Standard Shaft Length .....	15 = 15.0 mm 20 = 20.0 mm 25 = 25.0 mm 30 = 30.0 mm
Shaft Style .....	F = Metal Flatted Shaft K = Metal Knurled Shaft <sup>1</sup>
Switch Configuration .....	S = Push Momentary Switch N = No Switch
Resolution .....	0012 = 12 Pulses per 360 ° Rotation 0018 = 18 Pulses per 360 ° Rotation 0024 = 24 Pulses per 360 ° Rotation

<sup>1</sup> Metal knurled shaft with no switch is available in 15, 20 and 30 mm shaft lengths.  
Metal knurled shaft with push momentary switch is available in 15 and 20 mm shaft lengths.

\*RoHS Directive 2002/95/EC Jan 27 2003 including Annex.

\*\*Devices are tested using standard noise reduction filters. For optimum performance, designers should use noise reduction filters in their circuits.

Specifications are subject to change without notice.

Customers should verify actual device performance in their specific applications

## Quadrature Output Table

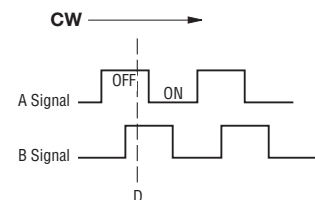

# PEC11 Series - 12 mm Incremental Encoder

**BOURNS®**

## Product Dimensions

### PEC11-4xxxF-Nxxxx

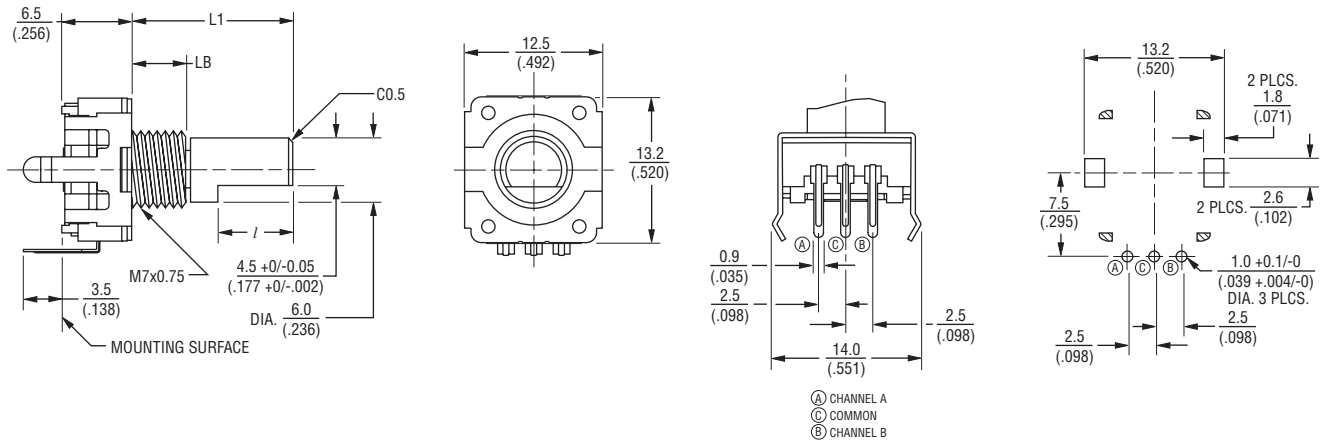

### PEC11-4xxxF-Sxxxx

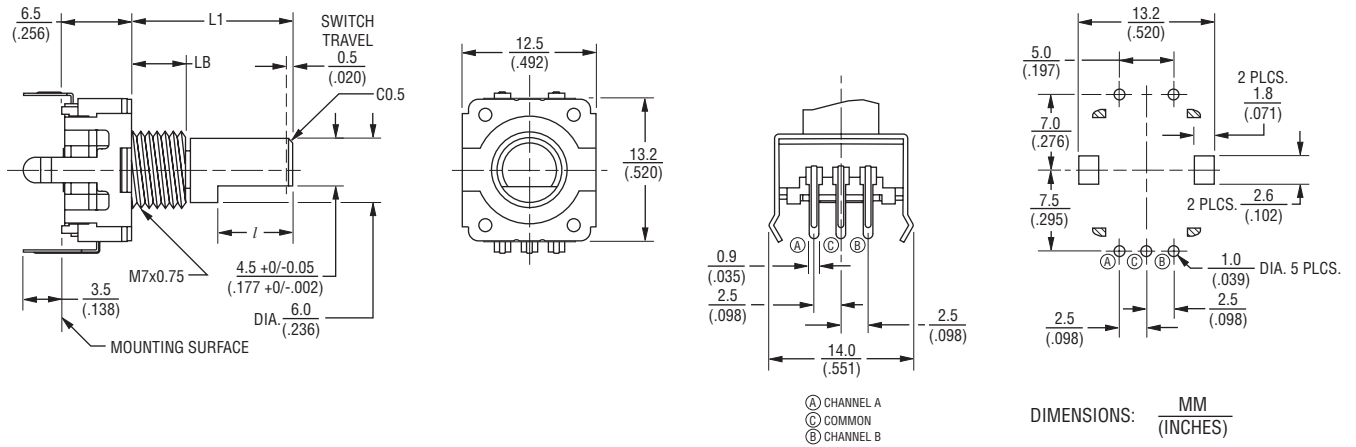

DIMENSIONS:  $\frac{\text{MM}}{\text{(INCHES)}}$

L1	LB	l
15 (.591)	5.0 (.197)	7.0 (.276)
20 (.787)	7.0 (.276)	10.0 (.394)
25 (.984)	7.0 (.276)	12.0 (.472)
30 (1.181)	7.0 (.276)	12.0 (.472)

# PEC11 Series - 12 mm Incremental Encoder

**BOURNS®**

## Product Dimensions

### PEC11-4xxxK-Nxxxx

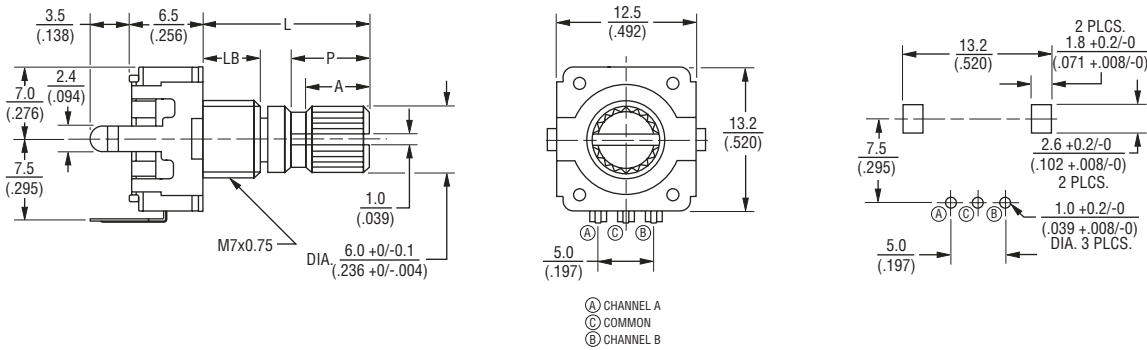

L	LB	P	A
15 (.591)	5.0 (.197)	7.0 (.276)	6.0 (.236)
20 (.787)	7.0 (.276)	7.0 (.276)	6.0 (.236)
30 (1.181)	7.0 (.276)	16.0 (.630)	12.0 (.472)

### PEC11-4xxxK-Sxxxx

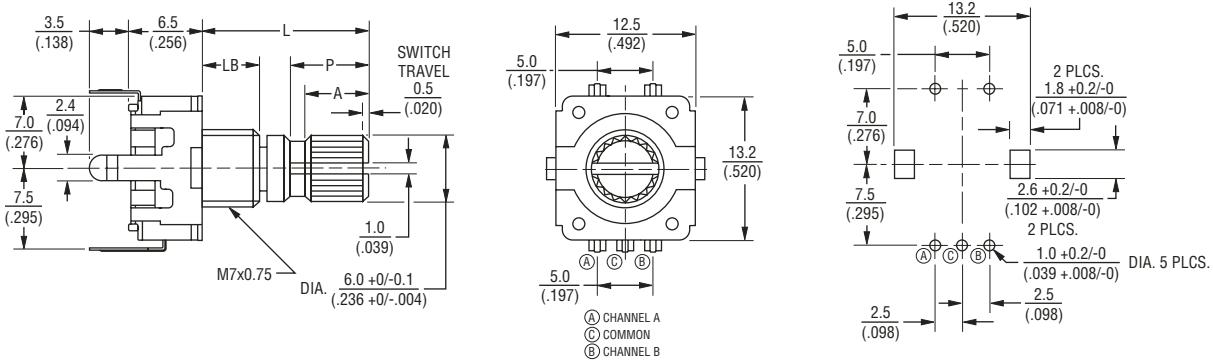

L	LB	P	A
15 (.591)	5.0 (.197)	7.0 (.276)	6.0 (.236)
20 (.787)	7.0 (.276)	7.0 (.276)	6.0 (.236)

DIMENSIONS:  $\frac{\text{MM}}{\text{(INCHES)}}$